



TABOR 12K

SPECIFICATIONS

Steel (ST): W12-01-97015

Synthetic (SY): W12-01-97055

Rated Line Pull: 5443 kg single-line

Motor: 12V DC Series Wound

Electrical Controls: Solenoid

Remote Control: Remote switch, 3.7m lead

Geartrain: 3-Stage Planetary

Gear Ratio: 216:1

Clutch (freespooling): Sliding Ring Gear

Brake: Automatic mechanical cone brake

Drum diameter/Length: 64mm/230mm

Rope: 24.3m/9.5mm (ST),

27.4m/9.5mm (SY)

Fairlead: Roller (ST), Hawse (SY)

Recommended Battery: 650 CCA minimum for winching

Battery leads: 2 gauge, 1.83m

Finish: Powder coat

Line Pull	Line Speed	Motor	Pull by Layer
kg	m/min	Current	Layer/Kg
0	8.6	65 amps	1/5443
910	3.8	144 amps	2/4317
1810	2.8	215 amps	3/3577
2720	2.2	281 amps	4/3054
3630	1.7	349 amps	5/2663
4540	1.3	415 amps	
5443	1.0	457 amps	

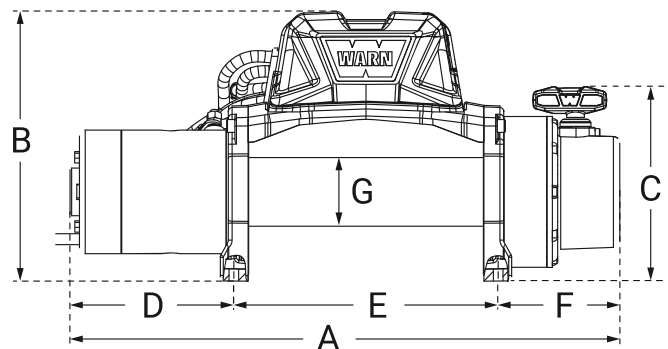

A. 554.5mm C. 160.1mm E. 254.0mm G. 63.5mm

B. 249.1mm D. 183.6mm F. 116.8mm

Mounting bolt pattern: 254.0mm x 114.3mm



Use More Of Your Vehicle
www.fullyequipped.co.nz

