



## TABOR 8K

### SPECIFICATIONS

**Steel (ST):** W08-01-96995

**Synthetic (SY):** W08-01-97000

**Rated Line Pull:** 3629 kg single-line

**Motor:** 12V DC Series Wound

**Electrical Controls:** Solenoid

**Remote Control:** Remote switch, 3.7m lead

**Geartrain:** 3-Stage Planetary

**Gear Ratio:** 216:1

**Clutch (freespooling):** Rotating Ring Gear

**Brake:** Automatic Direct Drive Cone

**Drum diameter/Length:** 64mm/230mm

**Rope:** 24.3m/9.5mm (ST),

27.4m/9.5mm (SY)

**Fairlead:** Roller (ST), Hawse (SY)

**Recommended Battery:** 650 CCA minimum for winching

**Battery leads:** 2 gauge, 1.83m

**Finish:** Powder coat

Line Pull	Line Speed	Motor	Pull by Layer
kg	m/min	Current	Layer/Kg
0	8.8	69.2 amps	1/3630
910	4.3	179.2 amps	2/2969
1810	3	281 amps	3/2512
2720	2.2	381 amps	4/2177
3630	1.4	457 amps	5/1921

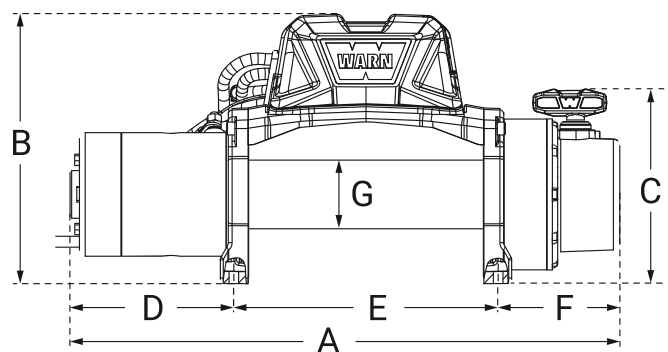

A. 527.0mm C. 160.0mm E. 254.0mm G. 63.5mm  
 B. 249.1mm D. 157.4mm F. 115.7mm

Mounting bolt pattern: 254.0mm x 114.3mm



Use More Of Your Vehicle  
[www.fullyequipped.co.nz](http://www.fullyequipped.co.nz)

