

**Satin-Black Powder-Coated Finish**

The black look that attracts compliments while it resists corrosion.

**Convertible Control Pack**

Lets you mount the control pack separately from the winch, or keep it attached for an integrated look. Your choice.

**Contractor Control**

Another piece in the durability and reliability puzzle: Built to weather the storm for the long run.

**New Motor and Motor Housing**

Hello extra power and durability; goodbye loud noise and exposed wires.

**Fast Line Speed, Low Amp Draw**

Maximize your winch line speed while you minimize the strain on your charging system.

**Stainless Steel Hardware**

Corrosion resistance runs deep in this winch construction.

**Extreme Waterproofing**

Meets rigorous IP68 standards—the highest rating in the WARN Truck/SUV winch lineup.

**Automatic Mechanical Brake**

Powerful brake holds the full-rated load and provides great control while winching.

**Three-Stage Planetary Gear Train**

It's about as fast and reliable as a gear train gets. Plus a new ergonomic easy-throw clutch lever.

**Hawse Fairlead**

Lightweight aluminum, with powder-coat finish.

**Synthetic Rope**

80 ft. of severe-duty, industrial-grade Spydura Pro synthetic rope found on many military vehicles.

**Aluminium Drum Design**

Large diameter for less wear on the winch rope. Includes an exclusive rope anchor point for easy winch rope replacement.

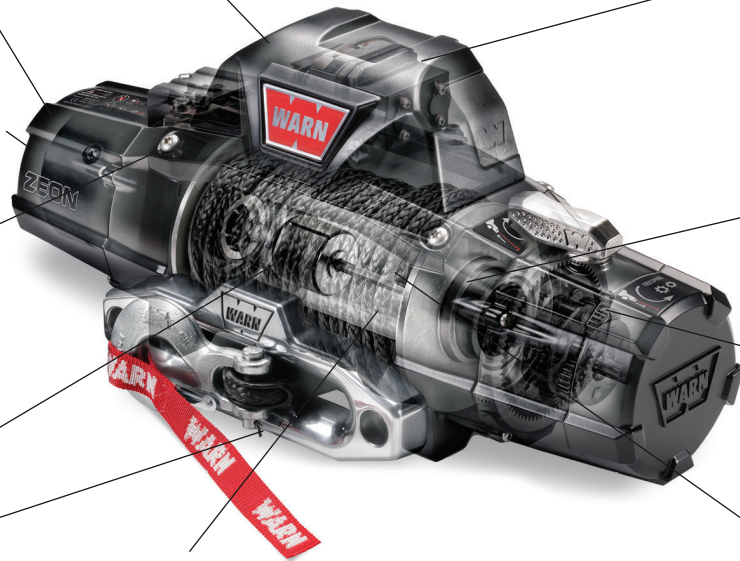

## ZEON 10K

### SPECIFICATIONS

**Steel (ST):** W10-02-89650

**Synthetic (SY):** W10-02-89680

**Rated Line Pull:** 4536 kg single-line

**Motor:** 12V DC Series Wound

**Electrical Controls:** Contactor

**Remote Control:** Remote switch, 3.7m lead

**Geartrain:** 3-Stage Planetary

**Gear Ratio:** 216:1

**Clutch (freespooling):** Rotating Ring Gear

**Brake:** Automatic Mechanical Cone

**Drum diameter/Length:** 80mm/229mm

**Rope:** 30.5m/9.5mm (ST),

30.5m/9.5mm (SY)

**Fairlead:** Roller (ST), Roller (SY)

**Recommended Battery:** 650 CCA minimum for winching

**Battery leads:** 2 gauge, 1.83m

**Finish:** Satin black powder coat

Line Pull	Line Speed	Motor	Pull by Layer
kg	m/min	Current	Layer/Kg
0	10.27	62 amps	1/4536
910	4.5	144 amps	2/3740
1810	3.4	215 amps	3/3182
2720	2.6	380 amps	4/2769
3630	2.0	353 amps	5/2450
4536	1.5	409 amps	

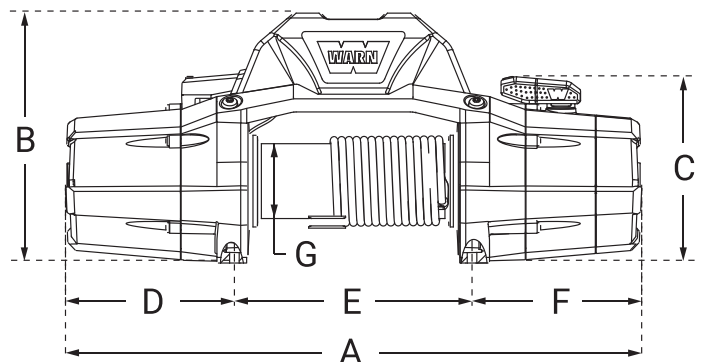

A. 615.9mm C. 199.0mm E. 254.0mm G. 80.0mm

B. 266.8mm D. 180.6mm F. 181.3mm

Mounting bolt pattern: 254.0mm x 114.3mm



Use More Of Your Vehicle  
www.fullyequipped.co.nz

