

Extreme Durability

Our highest durability rating—2X that of the previous generation. 4340 steel gears, durable structure and finish delivers maximum corrosion resistance—exceeding 400 hours of salt-spray testing.

High Performance Package

All-new high-speed motor, stronger gears, and heat-treated ring gear deliver 20% faster line speed, best-in-class efficiency, and our highest durability rating.

Large Diameter Drum

Zinc/aluminum alloy winch drum is strong, light weight, reduces rope wear, and has an integrated rope anchor for easy rope installation.

Automatic Mechanical Cone Brake

High-strength brake with steel sleeve-in-drum design is durable and holds the full rated load.

Contractor and Advanced Controls

Ratchets up the reliability factor. Controls are potted and sealed for the ultimate in waterproof protection.

Extreme Waterproofing

Meets rigorous IP68 standards—the highest rating in the WARN Truck/SUV winch lineup.

Remote Controlled Clutch

Engage and disengage with the Advanced Wireless Remote. The Remote controls winch-in, winch-out, and freespool operations. No more engaging a manual clutch while knee deep in mud.

Synthetic Rope

80 ft. of severe-duty, industrial-grade Spydura Pro synthetic rope found on many military vehicles.

The Advanced Wireless Remote

Allows you to control the winch and up to two accessories, plus it provides operator feedback.

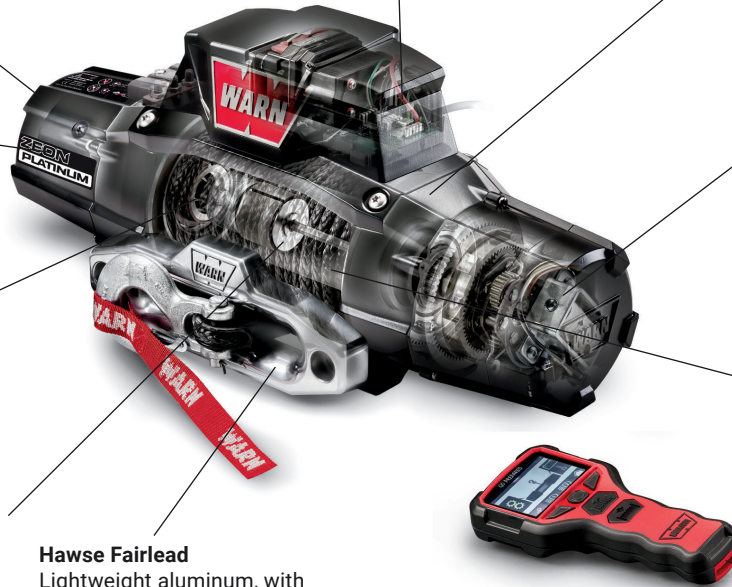

Hawse Fairlead
Lightweight aluminum, with powder-coat finish.

ZEON PLATINUM 10K

SPECIFICATIONS

Steel (ST): W10-03-92830

Synthetic (SY): W10-03-93680

Rated Line Pull: 4536 kg single-line

Motor: 12V DC Series Wound

Electrical Controls: Contactor

Remote Control: Advanced Wireless

Geartrain: 3-Stage Planetary

Gear Ratio: 162:1

Clutch (freespooling): Rotating Ring Gear

Brake: Automatic Mechanical Cone

Drum diameter/Length: 80mm/229mm

Rope: 24.4m/9.5mm (ST),

24.4m/9.5mm (SY)

Fairlead: Roller (ST), Hawse (SY)

Recommended Battery: 650 CCA minimum for winching

Battery leads: 2 gauge, 1.83mm

Finish: Satin black powder coat

Line Pull	Line Speed	Motor	Pull by Layer
kg	m/min	Current	Layer/Kg
0	13.4	55 amps	1/4536
910	5.42	149 amps	2/3740
1810	3.65	233 amps	3/3182
2720	3.3	311 amps	4/2769
3630	2.3	387 amps	5/2450
4536	1.7	465 amps	

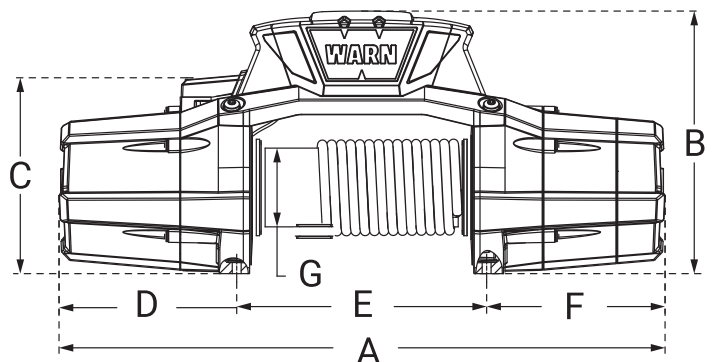

A. 615.9mm C. 199.0mm E. 254.0mm G. 80.0mm
B. 266.8mm D. 180.6mm F. 181.3mm

Mounting bolt pattern: 254.0mm x 114.3mm



Use More Of Your Vehicle
www.fullyequipped.co.nz

