

Extreme Durability

Our highest durability rating—2X that of the previous generation. 4340 steel gears, durable structure and finish delivers maximum corrosion resistance—exceeding 400 hours of salt-spray testing.

High Performance Package

All-new high-speed motor, stronger gears, and heat-treated ring gear deliver 20% faster line speed, best-in-class efficiency, and our highest durability rating.

Large Diameter Drum

Zinc/aluminum alloy winch drum is strong, light weight, reduces rope wear, and has an integrated rope anchor for easy rope installation.

Automatic Mechanical Cone Brake

High-strength brake with steel sleeve-in-drum design is durable and holds the full rated load.

Contractor and Advanced Controls

Ratchets up the reliability factor. Controls are potted and sealed for the ultimate in waterproof protection.

Extreme Waterproofing

Meets rigorous IP68 standards—the highest rating in the WARN Truck/SUV winch lineup.

Remote Controlled Clutch

Engage and disengage with the Advanced Wireless Remote. The Remote controls winch-in, winch-out, and freespool operations. No more engaging a manual clutch while knee deep in mud.

Synthetic Rope

80 ft. of severe-duty, industrial-grade Spydura Pro synthetic rope found on many military vehicles.

The Advanced Wireless Remote

Allows you to control the winch and up to two accessories, plus it provides operator feedback.

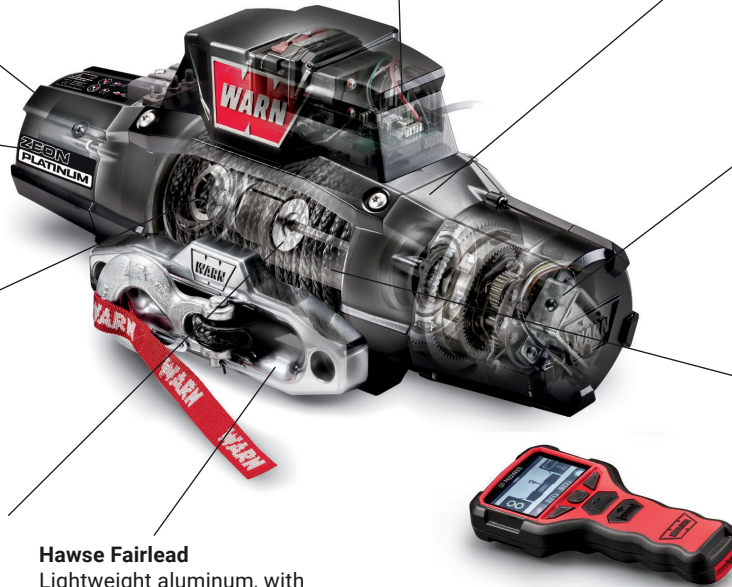

ZEON PLATINUM 12K

SPECIFICATIONS

Steel (ST): W12-03-93685

Synthetic (SY): W12-03-96035

Rated Line Pull: 5443 kg single-line

Motor: 12V DC Series Wound

Electrical Controls: Contactor

Remote Control: Advanced Wireless

Geartrain: 3-Stage Planetary

Gear Ratio: 216:1

Clutch (freespooling): Rotating Ring Gear

Brake: Automatic Mechanical Cone

Drum diameter/Length: 80mm/229mm

Rope: 24.4m/9.5mm (ST),

24.4m/9.5mm (SY)

Fairlead: Roller (ST), Hawse (SY)

Recommended Battery: 650 CCA minimum for winching

Battery leads: 2 gauge, 1.83m

Finish: Satin black powder coat

Line Pull	Line Speed	Motor	Pull by Layer
kg	m/min	Current	Layer/Kg
0	10.0	57 amps	1/5440
910	4.6	132 amps	2/4488
1810	3.0	200 amps	3/3818
2720	2.7	261 amps	4/3323
3630	2.4	321 amps	5/2941
4536	1.6	381 amps	
5440	1.4	446 amps	

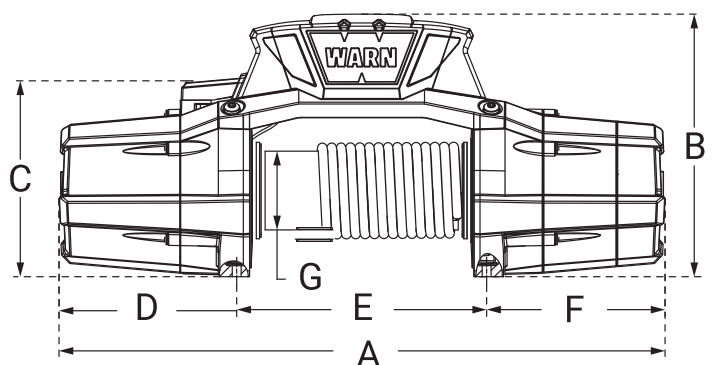

A. 615.9mm C. 199.0mm E. 254.0mm G. 80.0mm

B. 266.8mm D. 180.6mm F. 181.3mm

Mounting bolt pattern: 254.0mm x 114.3mm



Use More Of Your Vehicle
www.fullyequipped.co.nz

